

SA|Eng.

Soluzioni per l'Ambiente



SA2 - 2000

TWO SHAFTS SHREDDER

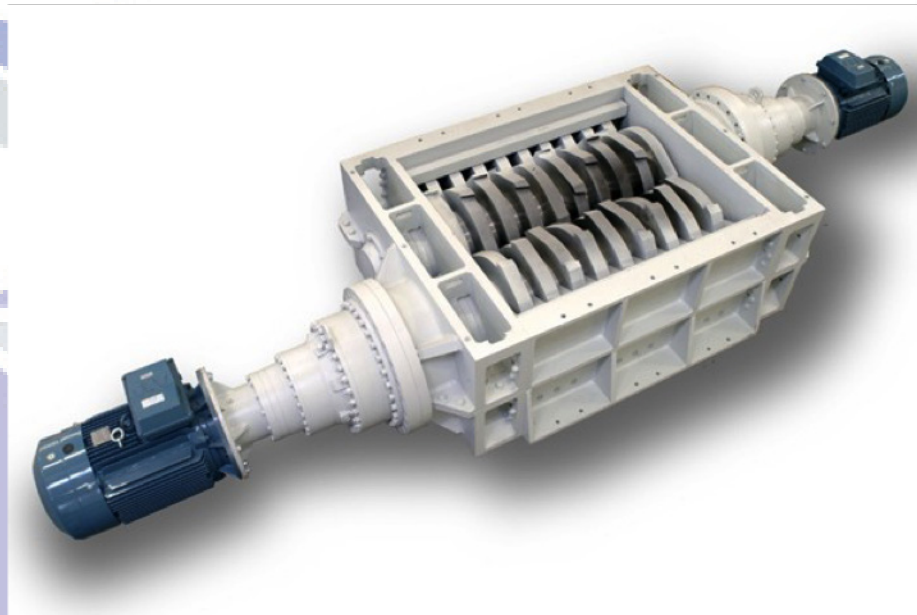

High torque machine with low speed shafts

- Shredding chamber size 2000 x 1300 mm
- Electric motor installed directly into the transmission system
- Low maintenance version with fast removal system of shafts and blades
 - Blades thickness 75 mm
- Blades available on different material variable from the shredded wastes

Ideal for the treatment of:

Plastics - Tires - Wood - Electronic waste - Municipal waste



SA2 - 2000

TWO SHAFTS SHREDDER

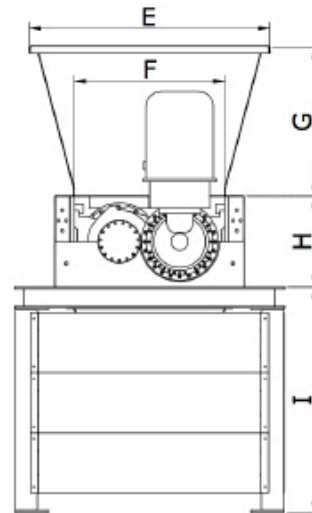
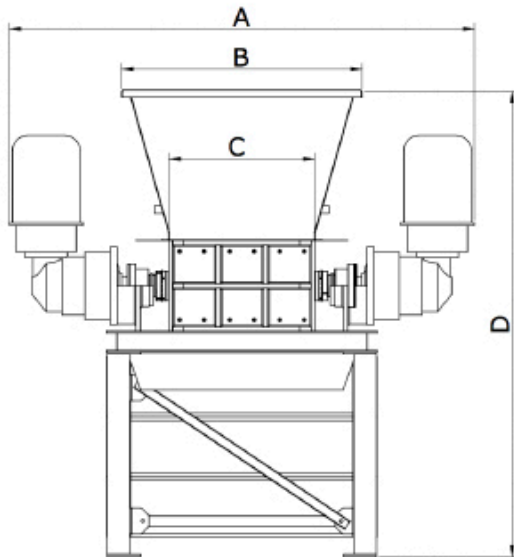

Dimensioni	
A:	3900
B:	2500
C:	2050
D:	4000
E:	1800
F:	1300
G:	1200
H:	800
I:	1990



Visit our website

You're welcome !!
Come to visit us



TECHNICAL DETAILS:

• Shredding chamber

- Chamber size	mm	2000 x 1300 x 800
- Number of shafts	n.	2
- Shafts speed	rpm	21/18
- Number of blades	n.	26
- Blades thickness	mm	75
- Kind of blades		with 4 hook
- Gearboxes	n.	2
- Trasmission system		Direct

• Drive system

- Electric motor	n.	2
- Installed power	kW	2 x 37
	HP	100
	V	400
- Control system		by PLC

• Machine weight

Kg 10000 ca.

Technical characteristics can be change without notice

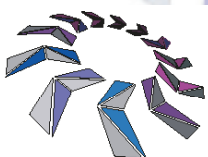

SA|Eng.
Soluzioni per l'Ambiente

Legal office and North East Italy representation: Via Noventa, 80 - San Donà di Piave (VE)
Operative office, Export and North West Italy representation: Via Della Filanda, 9 - Arluno (Mi)
Tel: +39 02 22 19 1230 www.sa-eng.it info@sa-eng.it